



## SERIES BW3250

### BLAST RESISTANT CURTAIN WALL

---

#### NOTE

THE INSTALLATION DETAILS FOUND IN THIS PACKAGE ARE GENERIC AND ARE FOR REPRESENTATION ONLY WITH THE INTENT OF GIVING THE INSTALLATION TEAM A VISUAL REPRESENTATION AS TO HOW THE ASSEMBLIES TYPICALLY INSTALL. THE SHOP SUBMISSION DRAWINGS AND DETAILS ARE THE GOVERNING DOCUMENTS AND AS SUCH THIS PACKAGE IS TO BE USED ONLY AS A RESOURCE

FOLLOW SEALANT MANUFACTURERS' RECOMMENDATIONS FOR USE AND APPLICATION OF ALL STRUCTURAL SILICONE SEALANT AND WEATHER SEAL SILICONE SEALANT.

CUSTOMER/PROJECT QUALITY ASSURANCE PROCEDURES ARE SEPARATE DOCUMENTS AND ARE TO BE FOLLOWED IN CONJUNCTION WITH THIS MANUAL.

11M0177\_REV\_A\_11.21

# HANDLING, STORAGE, AND PROTECTION OF ALUMINUM

The following precautions are recommended to protect the material against damage. Following these precautions will help ensure early acceptance of your products and workmanship.

**A. HANDLE CAREFULLY.**

All aluminum materials at the job site must be stored in a safe place, well removed from possible damage by other trades. Cardboard wrapped or paper interleaved materials must be kept dry.

**B. CHECK ARRIVING MATERIALS.**

Check for quantity counts and keep records of where various materials are stored.

**C. KEEP MATERIALS AWAY FROM WATER, MUD, AND SPRAY.**

Prevent cement, plaster, or other materials from damaging the finish.

**D. PROTECT THE MATERIALS AFTER ERECTION.**

Protect erected frame with polyethylene or canvas splatter screen. Cement, plaster, terrazzo, other alkaline solutions, and acid based materials used to clean masonry are harmful to the finish. ***If any of these materials come in contact with the aluminum, immediately remove with water and mild soap.***

The rapidly changing technology within the architectural aluminum products industry demands that U.S. Aluminum reserve the right to revise, discontinue or change any product line, specification or electronic media without prior written notice.

**NOTE:** Dimensions in parentheses ( ) are millimeters unless otherwise noted.

[usalum.com](http://usalum.com)

V 2024-1007

Copyright © 2021 US Aluminum

All rights reserved.

™ ® Trademarks of US Aluminum and its affiliated companies or respective owners.

# GENERAL INSTALLATION NOTES

## Recommended guidelines for all installations:

- 1. REVIEW CONTRACT DOCUMENTS.** Check shop drawings, installation instructions, architectural drawings, and shipping lists to become thoroughly familiar with the project. The shop drawings take precedence and include specific details for the project. Note any **field verified** notes on the shop drawings prior to installing. The installation instructions are of a general nature and cover most conditions.
- 2. INSTALLATION.** All materials are to be installed plumb, level, square, and true.
- 3. INSTALLER QUALIFICATION.** The **Series BW3250** curtain wall system is intended for fabrication, assembly, sealing, installation and glazing by professionals with appropriate knowledge and experience of the system(s) and their incorporation into various building conditions.
- 4. BENCH MARKS.** All work should start from bench marks and/or column lines as established by the architectural drawings and the general contractor with guaranteed accuracy. Working from these datum points and lines determine:
  - a) The plane of the wall in reference to offset lines provided on each floor.
  - b) The finish floor lines in reference to bench marks on the outer building columns.
  - c) Mullion spacing from both ends of masonry opening to prevent dimensional build-up of daylight opening.
- 5. STEEL ANCHORS.** Steel anchors that weld to steel structure are normally line set before mullions are hung. Outstanding leg of anchors must be at 90 degrees to offset lines. Mullion space should be held to  $\pm 1/32"$  (0.8). Anchor clips vary per job conditions. Follow approved shop drawings for size and location of clips.
- 6. FIELD WELDING.** All field welding must be adequately shielded to avoid any splatter on glass or aluminum. Results will be unsightly and/or structurally unsound. Advise general contractor and other trades accordingly. All field welds of steel anchors must receive touch-up paint (zinc chromate) to avoid rust.
- 7. SURROUNDING CONDITIONS.** Make certain that construction which will receive your materials is in accordance with the contract documents. If not, notify the general contractor in writing and resolve differences before proceeding with work.
- 8. ISOLATION OF ALUMINUM.** Aluminum to be placed in direct contact with uncured masonry or incompatible materials should be isolated with a heavy coat of bituminous paint. For steel reinforcement primer, use manufacturer's standard corrosion resistant primer, meeting or exceeding Sherwin Williams Kem Kromik® and ASTM D5894, 1008 Corrosion Resistance.
- 9. SEALANTS.** The fabrication and installation of a structural silicone-glazed (SSG) or wet glazed system requires more technical knowledge and experience than is required for a conventional pressure-glazed or dry glazed system. The glazing contractor should take all steps as outlined and required by the structural silicone sealant manufacturer, glass fabricator, framing manufacturer, and the project professional engineer of record as well as follow local building code requirements and industry best practices to ensure the proper installation and safe performance of the SSG system.

The glazing contractor for each project needs to ensure compliance with each step, including, but not limited to, design reviews, formal adhesion testing, formal compatibility testing, project specification compliance, validating procedures, field testing, and quality control validation of installed product and surrounding conditions.

Testing of component materials for use in a SSG or wet glazed system is mandatory to fulfill project specifications and warranty requirements and must be submitted by the glazing contractor to the structural silicone manufacturer. All materials that comprise the structural silicone joint, such as the framing system (with the job-specific finish) and job-specific glass must be tested by the structural silicone manufacturer for compatibility and adhesion. All other accessory materials in contact with the structural silicone, such as setting blocks, spacers, gaskets, sweeps, air seals and expansion joints, must also be submitted to the silicone sealant manufacturer for compatibility testing.

To ensure that nothing has changed in formulation or chemistry since the initial tests, subsequent testing during periodic time frames of the project is to be conducted to confirm continued acceptance of the material for use on the project.

To ensure the structural performance and integrity of the insulating glass unit (IGU), the glazing contractor must submit the project shop drawings to the glass fabricator to obtain approval for use of their product(s) in any 2, 3 or 4-sided SSG applications.

Quality control procedures for field glazing are to be increased beyond those required for shop glazing. Job conditions will normally have dust, dirt, and other construction debris on the surfaces where structural silicone is to be applied. Great care should be exercised in cleaning and preparing these surfaces for silicone application. The recommendations of the silicone sealant manufacturer are to be strictly enforced and followed. The fabrication and installation of the SSG system and its components, whether shop or field glazed, should be governed by a quality control program, and all steps, procedures, and test reports should be documented throughout the project.

Prior to installation of any SSG system, refer to industry documents (e.g., AAMA Curtain Wall Design Guide Manual, ASTM C1401-14, and AAMA SSGDG-17) for detailed instructions and recommendations.

THE GLAZING CONTRACTOR ASSUMES FULL RESPONSIBILITY FOR ENSURING COMPLIANCE WITH THE ABOVE, AND ASSUMES FULL LIABILITY FOR ANY ISSUES ARISING FROM NONCOMPLIANCE.

[usalum.com](http://usalum.com)

V 2024-1007

Copyright © 2021 US Aluminum

All rights reserved.

™ ® Trademarks of US Aluminum and its affiliated companies or respective owners.

# GENERAL INSTALLATION NOTES CONT.

## Recommended guidelines for all installations:

10. **FASTENING.** Within the body of these instructions "fastening" means any method of securing one part to another or to adjacent materials. Only those fasteners used within the system are specified in these instructions. Due to the varying perimeter conditions and performance requirements, perimeter and anchor fasteners are not specified in these instructions. For perimeter and anchor fasteners refer to the shop drawings or consult the fastener supplier.
11. **BUILDING CODES.** Due to the diversity in state/provincial, local, and federal laws and codes that govern the design and application of architectural products, it is the responsibility of the individual architect, owner, and installer to assure that products selected for use on projects comply with all the applicable building codes and laws. U.S. Aluminum exercises no control over the use or application of its products, glazing materials, and operating hardware, and assumes no responsibility thereof.
12. **EXPANSION JOINTS.** Expansion joints and perimeter seals shown in these instructions and in the shop drawings are shown at normal size. Actual dimensions may vary due to perimeter conditions and/or difference in metal temperature between the time of fabrication and the time of installation. Gaps between expansion members should be based on temperature at time of installation.
13. **GLAZING PRACTICES.** The air and water performance of the **Series BW3250** curtain wall system is directly related to the completeness and integrity of the installation process, including but not limited to the assembly seals of the framing joinery, the installed glazing gaskets, and the alignment of the framing joinery glazing plane. Before glazing, verify the glazing pocket width and glazing infill thickness, as both must be in tolerance to assure adequate edge pressure and to achieve the desired air and water performance levels. (In general, framing systems utilizing 1" insulating glass are designed to accommodate a thickness variance of +/- 1/32"). Note: Excessive pressure can cause glass breakage and/or IGU failure. Consult the glass manufacturer for their recommended edge pressure per lineal inch.

To achieve the designed and tested air and water performance, best practices include:

- Glazing gaskets should be cut 1/4" longer per foot, and lay flat, preferably for 24 hours
- Gaskets should be cut as single monolithic pieces and "crowded" during their installation to avoid corner gaps caused by post-installation relaxation
- The interior glazing gasket should be installed so as to avoid stretching, buckles, or tears
- Corners must be cut square, and at a slight angle when required to conform to the bevel on the intersecting gasket; sealed and butted together.
- Gasket corner joinery must also be crowded, and sealant applied onto the gasket contact frame surface and into gasket reglet raceway where applicable.
- Gasket corner seals are to be done just prior to installing glass, while the sealant is still wet and uncured, and ensure exterior gaskets are installed so as to place the glass into its final in service condition and allow the sealant to conform to optimum configuration. Note: If the sealant cures prior to glazing, the cured sealant could create excessive edge pressure onto the glass and has the potential to cause glass breakage.
- The glass must be checked for squareness, size dimension, and thickness along the edges paying attention to any variances from center edge to corner edge
- Check the placement of the installed glass and verify there is proper edge bite into the pocket, and proper edge clearance from framing elements

After sealant has set and a representative amount of the wall has been installed and glazed (250 square feet or more) run a water hose test in accordance with AAMA 501.2 specifications to check installation. On large projects the hose test should be repeated during the glazing operation. Consult and follow NGA's GANA Manual and FGMA Glazing Manual for proper glazing technique and procedure.

14. **COORDINATION WITH OTHER TRADES.** Coordinate with the general contractor any sequence with other trades which offset curtain wall installation (i.e. fire proofing, back-up walls, partitions, ceilings, mechanical ducts, converters, etc.).
15. **CARE AND MAINTENANCE.** Final cleaning of exposed aluminum surfaces should be done in accordance with AAMA 609.1 for anodized aluminum and 610.1 for painted aluminum.

# SITE PREPARATION

## BEFORE INSTALLATION

1. Review and measure the opening.
2. Verify rough window opening size 1/2" (12.7) clearance in both width and height to the window. Verify framing is plumb, straight, and true around window opening. Measure opening at each end and at center vertically and horizontally. Make corrections to openings as required. Measure opening diagonally to check squareness. Chip concrete high points to flush and rounded corners to square.

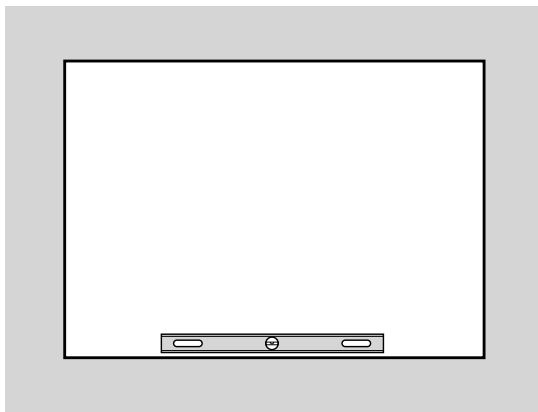

LEVEL

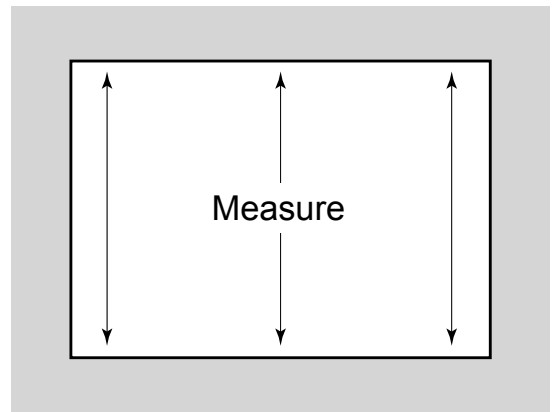

VERTICAL DIMENSION

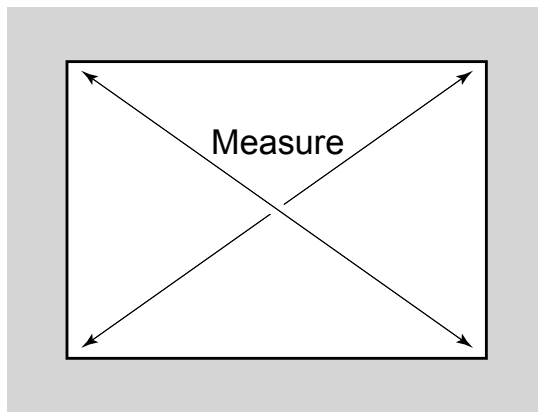

SQUARE

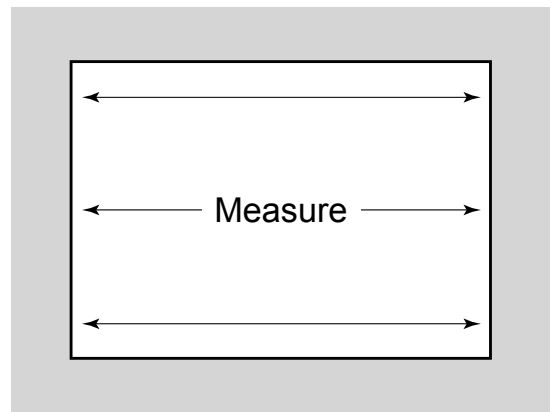

HORIZONTAL DIMENSION

# FABRICATION

## FRAME CUTTING

1. Cut members to size:

<b>Vertical Members</b>	Rough Opening (R.O.) Minus top and bottom clearances = Frame Height (F.H.).
<b>Vertical Pressure Bars</b>	F.H. Minus 1/4" (6.4)
<b>Vertical Face Caps</b>	F.H. Minus 1/32" (.8)
<b>Horizontal Members</b>	Day Light Opening (D.L.O.) Plus 0"
	(Cutting tolerances must not exceed D.L.O. dimension.)
<b>Horizontal Pressure Bars</b>	D.L.O. Minus 1/4" (6.4)
<b>Horizontal Face Caps</b>	D.L.O. Minus 1/32" (.8)

**NOTE: The vertical cut lengths shown above are for non-spliced conditions. For spliced vertical member cut lengths refer to approved shop drawings. See DETAIL V on page 16.**

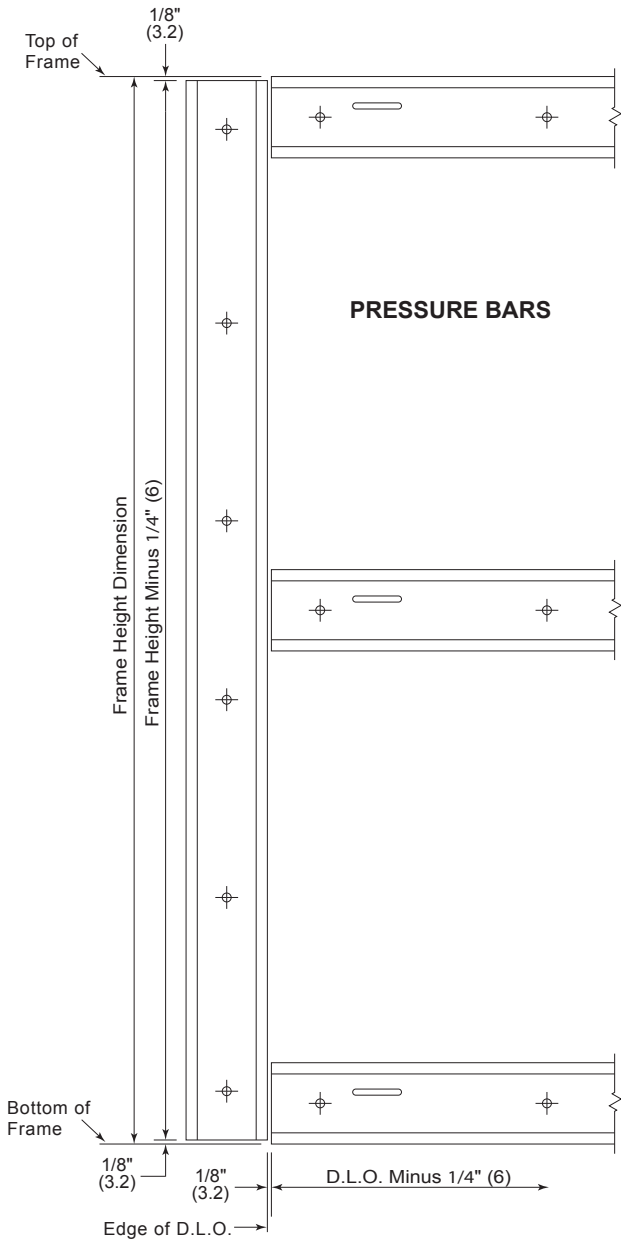

**DETAIL A**

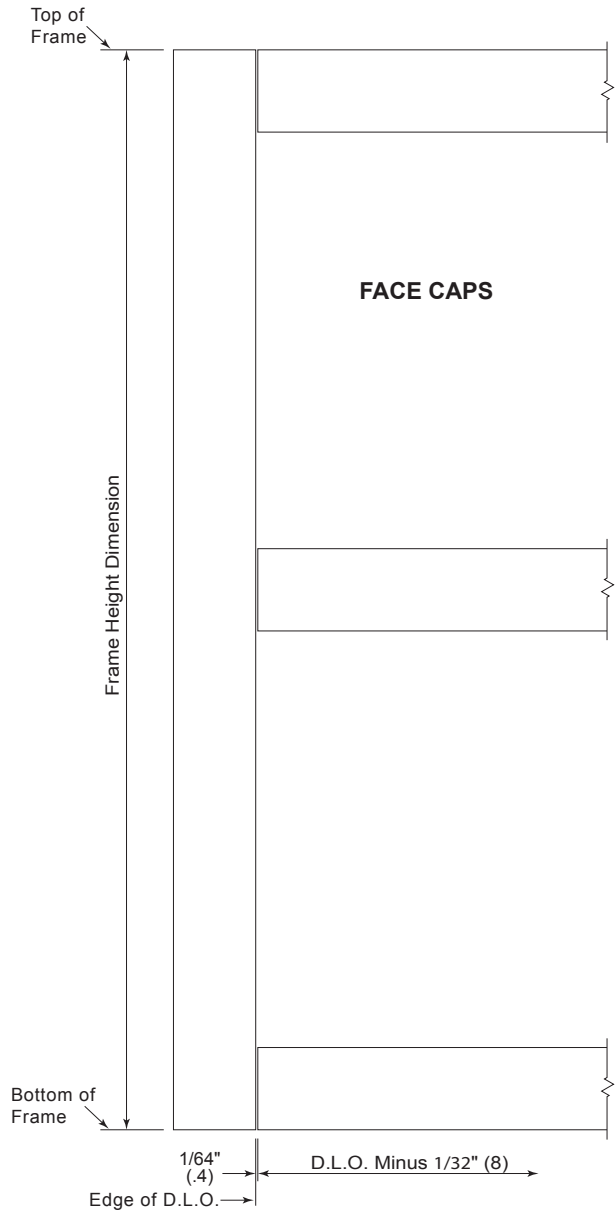

**DETAIL B**

NOT TO SCALE

# FABRICATION

## FABRICATE FOR SHEAR BLOCK

2. Mark on verticals the top of intermediate horizontal member locations. Align drill guide with mark as shown in **DETAIL C** and drill holes for shear blocks. Flush drill guide with top of vertical for head and bottom for sill. The drill guide locates pilot holes that must be enlarged to 11/32" (8.7) diameter or 21/32" (16.7) diameter as indicated in **DETAIL C** below for required load.

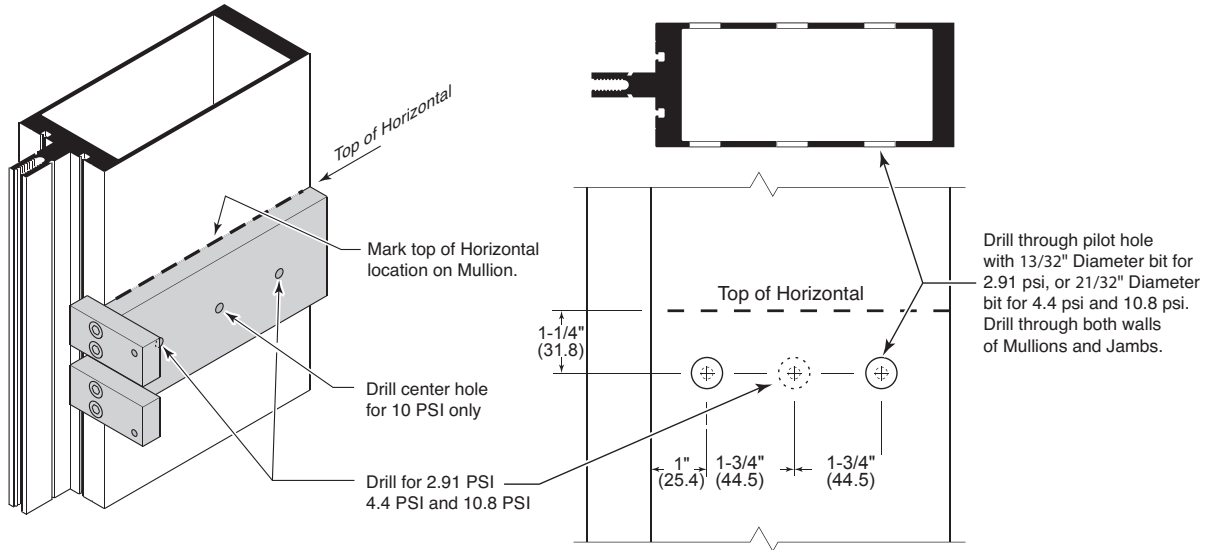

**DETAIL C**

3. Fabricate ends of horizontal members for shear block pick-up screws. See **DETAIL D** for drill usage.

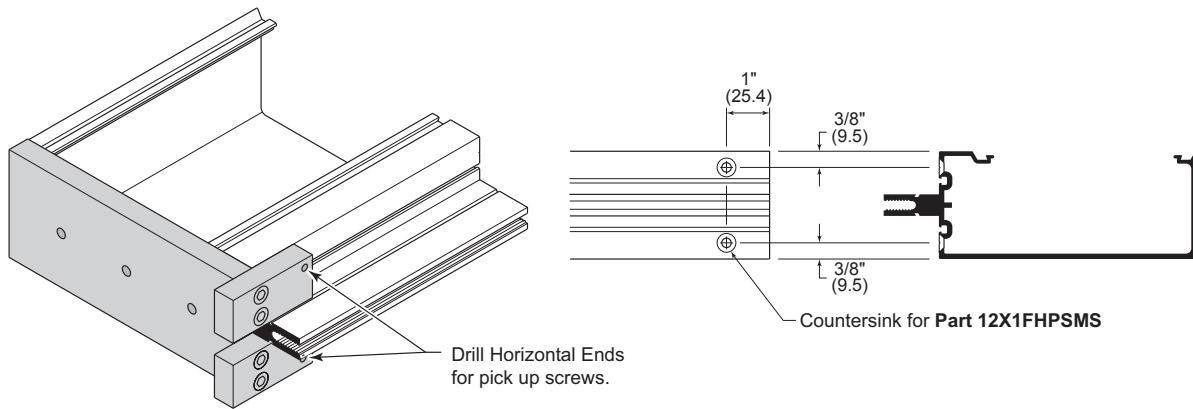

**DETAIL D**

4. Notch head and sill ends as shown in **DETAIL E** where head or sill caulk joint clearances are less than the typical 3/4" (19.5).

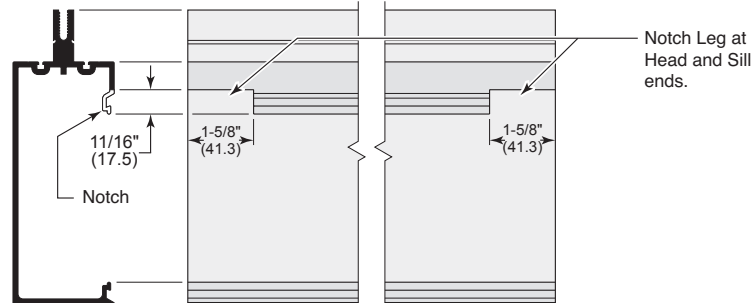

**DETAIL E**

NOT TO SCALE

# FABRICATION

## FABRICATE FOR CORNER SHEAR BLOCK

5. Fabricate corner mullion for tapping blocks and shear blocks as shown in **DETAIL F**.

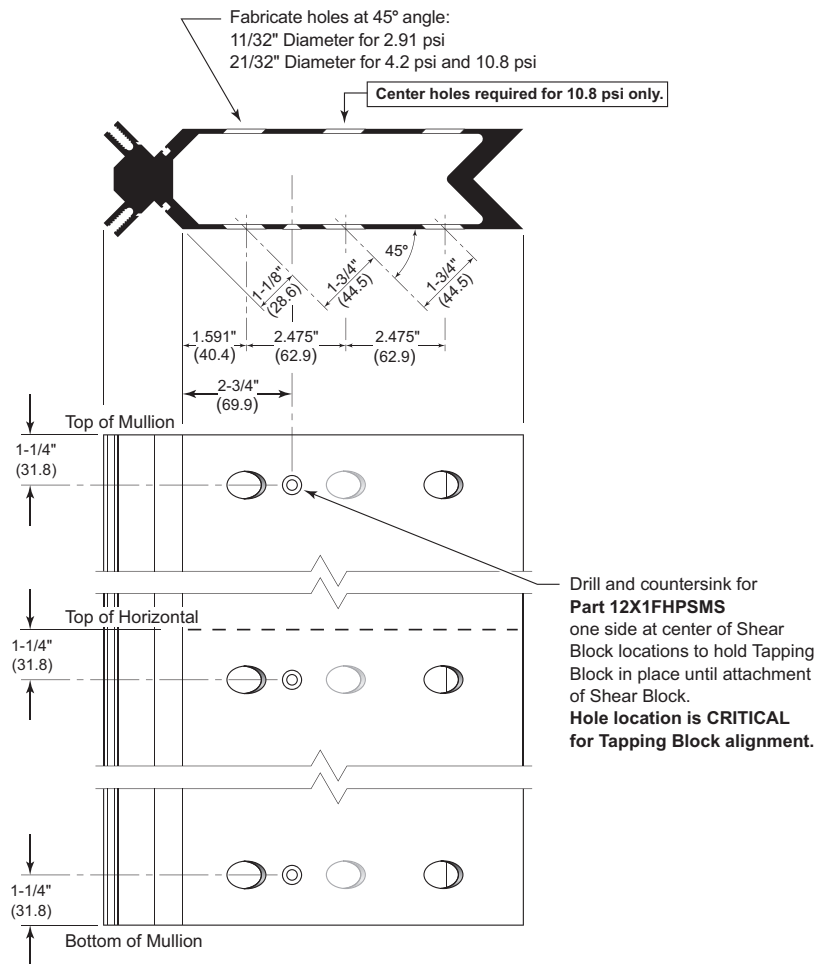

**DETAIL F**

6. Drill .182" diameter hole in tapping block to align with countersunk hole prep in corner mullion. See **DETAIL G**.

7. Slide tapping blocks into corner mullion centering on head, sill, and intermediate horizontal locations. Use (1) 12 X 1" FHP SMS (**Part 12X1FHPSMS**) to secure in place.

**NOTE: Check alignment of tapping block and mullion holes for shear block bolt engagement.**

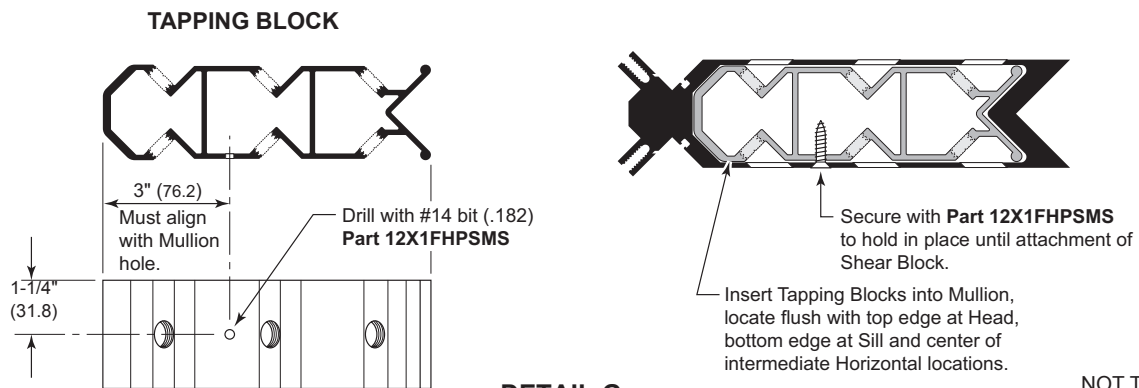

**DETAIL G**

NOT TO SCALE



# FABRICATION

## MID-SPAN ANCHOR PREPARATION

- Slide reinforcement sleeve into mullions centering on anchor location. Drill and countersink back of mullion for #12 X 1" FH SMS (Part 12X1FHPSMS) to hold anchor reinforcement sleeve in place. See DETAIL H.
- Drill two 17/32" diameter holes through mullion and reinforcement sleeve for anchor bolts. See DETAIL H.

**NOTE: Anchor bolt and drill hole sizes can vary per individual project. Consult approved shop drawings prior to fabrication.**

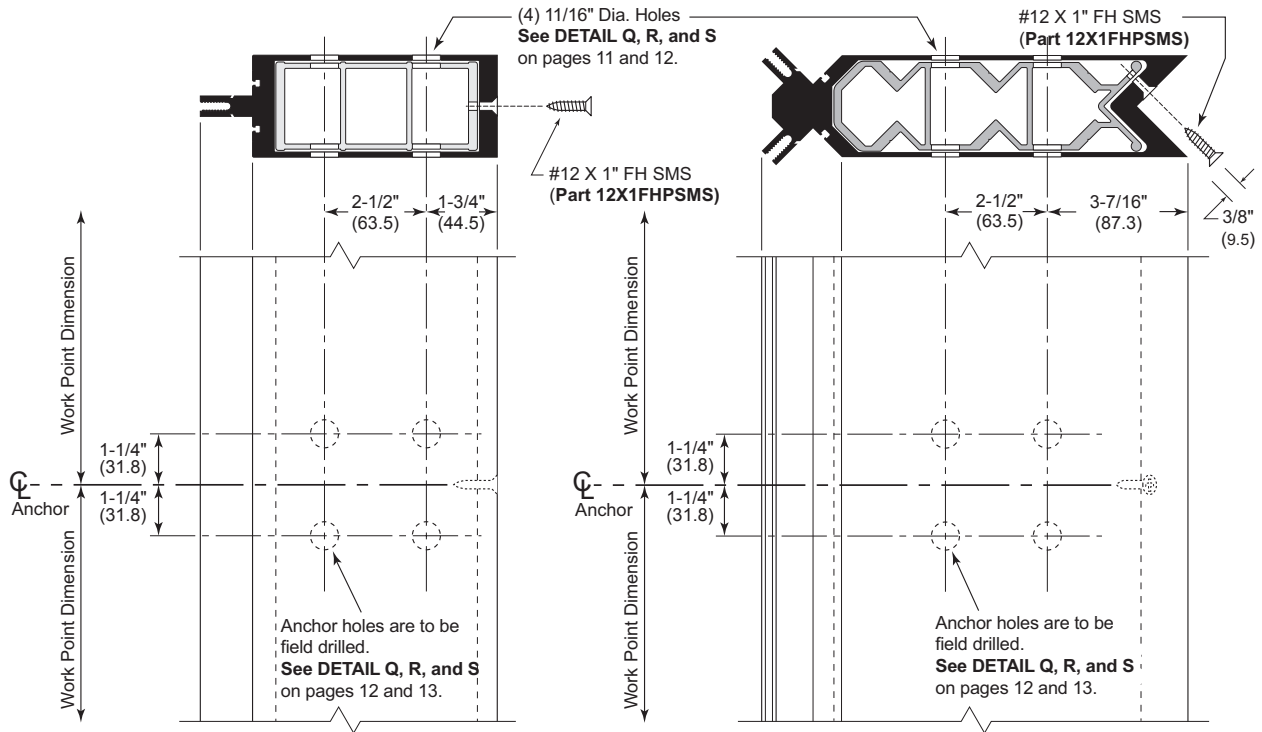

DETAIL H

- Fabricate slots in head and sill mullion anchors as required for loading. See DETAIL I.

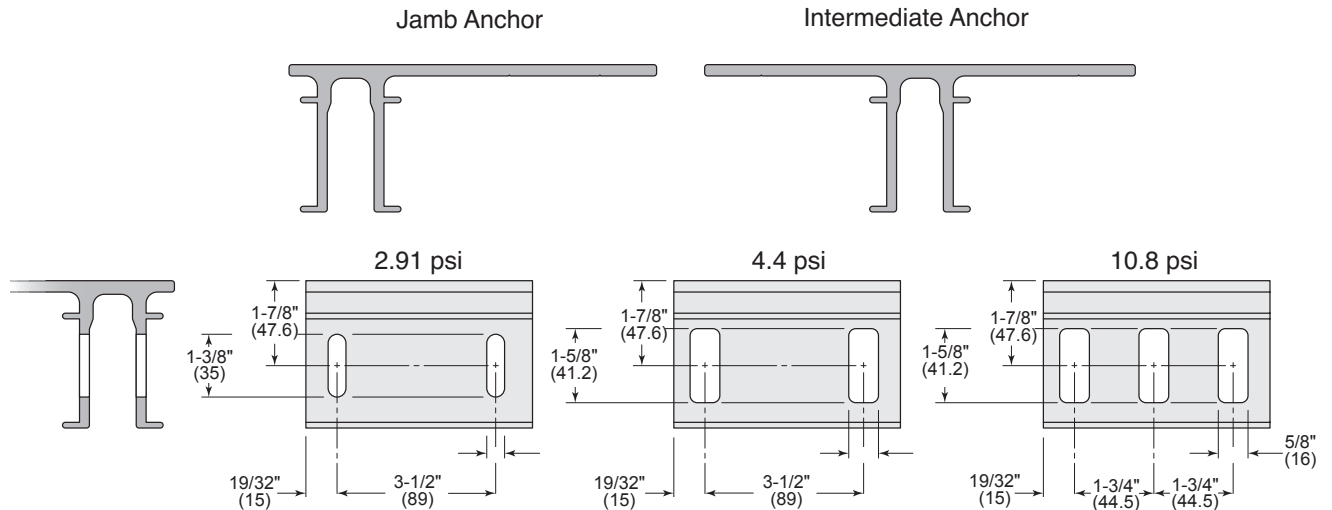

DETAIL I

NOT TO SCALE

# FABRICATION

## SPLICE JOINT FABRICATION

Splice joint width should be based on sealant movement capability and on the following formula:

Linear expansion for aluminum, in inches	= Length (")	x F° difference in temperature	x .000129
Linear expansion for aluminum, in millimeters	= Length (m)	x C° difference in temperature	x .02322

A 1/2" (12.7) minimum joint is recommended. Use a spacer shim to set and hold the mullion joint constant during erection. Remove the shim after attaching the verticals to the anchors. Splice joints must occur in spandrel areas.

**NOTE:** Splice joints accommodate thermal movement only. They do not compensate for variations in floor levels.

11. Fabricate lower mullions for splice attachment screws as shown in **DETAIL J**.
12. Fabricate back of mullions for stop screw. Install stop screw. See **DETAIL J**.

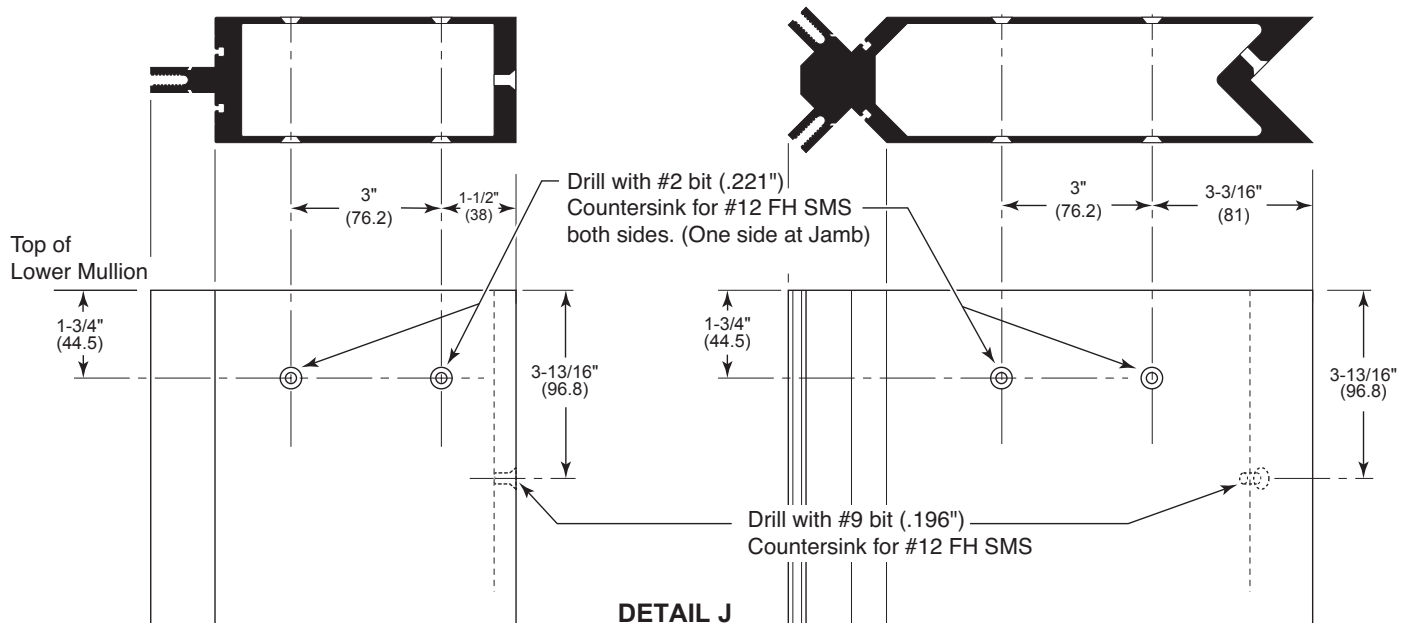

13. Clean splice sleeves and all joint surfaces. Apply bond breaker tape at areas where sleeve will be sealed to avoid three side adhesion. See **DETAIL K**.
14. Slide splice sleeve into the upper member before erection and tape to hold in place. See **DETAIL K**.

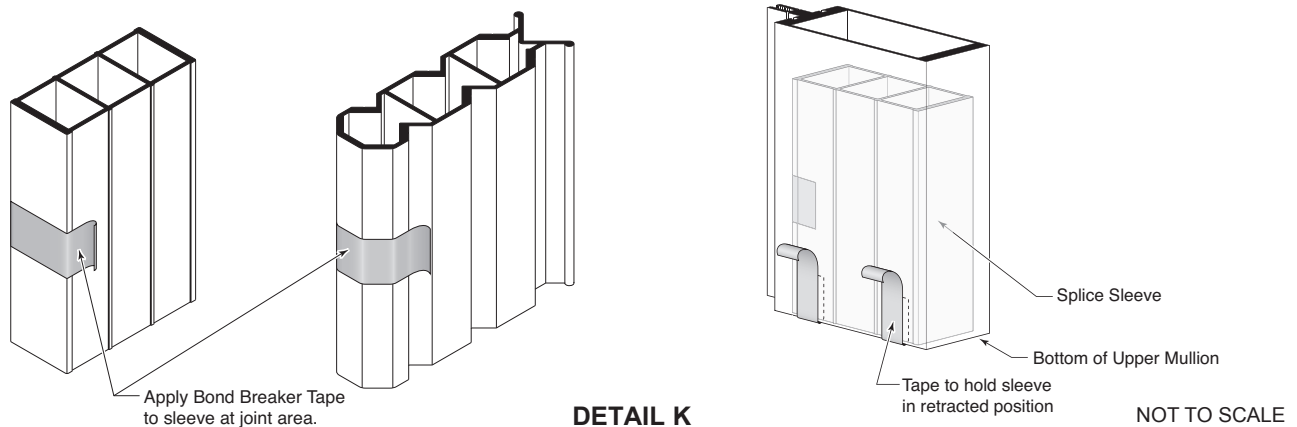

# FABRICATION

## PRESSURE BAR AND FACE CAP FABRICATION

15. Pressure bars are supplied with 9/32" (7.1) dia. holes at 9" (228.6) O.C. for attachment bolts. Additional holes are to be drilled 1-1/2" (38.1) from all ends and at vertical/horizontal intersections. **See DETAIL L.**
16. Fabricate two 3/16" x 1-1/2" (4.8 x 38) weep slots in horizontal pressure bars as shown on **DETAIL L.**
17. Fabricate horizontal face caps by drilling 1/4" (6.4) dia. weep holes in bottom of cap at 6" (152.4) from each end as shown on **DETAIL M.**

**PRESSURE BAR FABRICATION**

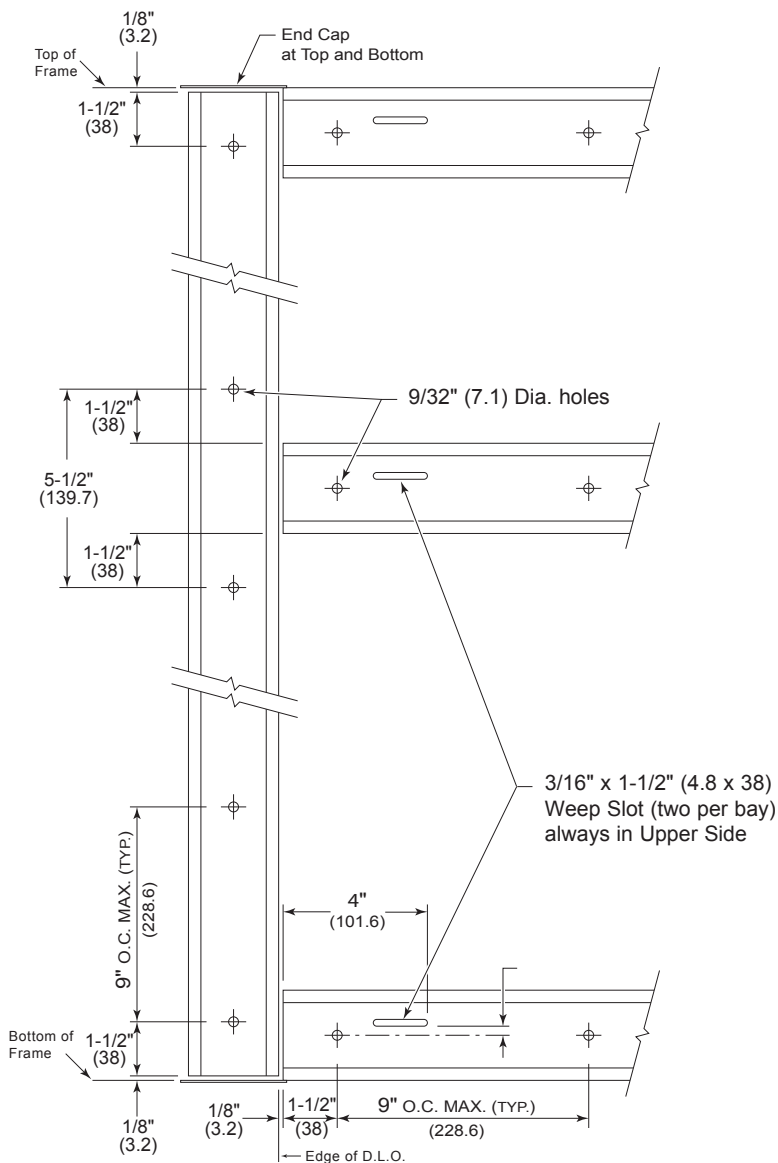

**FACE CAP FABRICATION**

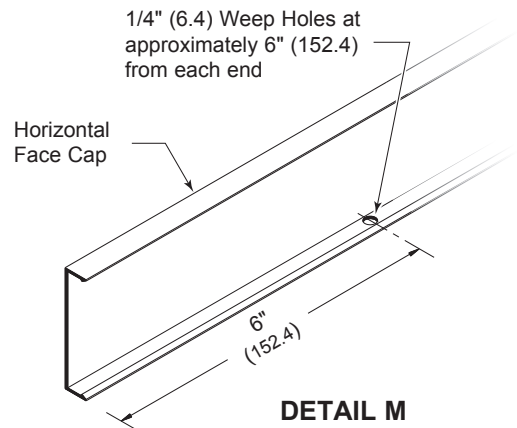

**DETAIL M**

**NOTE: Weep Slots are required in all Horizontal Pressure Bars including the Head or Top Horizontal**

**DETAIL L**

# ASSEMBLY AND INSTALLATION

## SINGLE SPAN CONDITION

1. Slide top and bottom "T" anchors into vertical members. **See DETAIL N and O.**  
For corner **see DETAIL P** on page 13.
2. Install verticals plumb and level. Shim under both sides of mullion as required to adjust bottom to proper level. Shims are required under each side for proper load distribution. Secure top and bottom anchors to structure.

**NOTE:**  
Center bolt in Shear Block is required for 10.8 psi conditions only. (Shown)

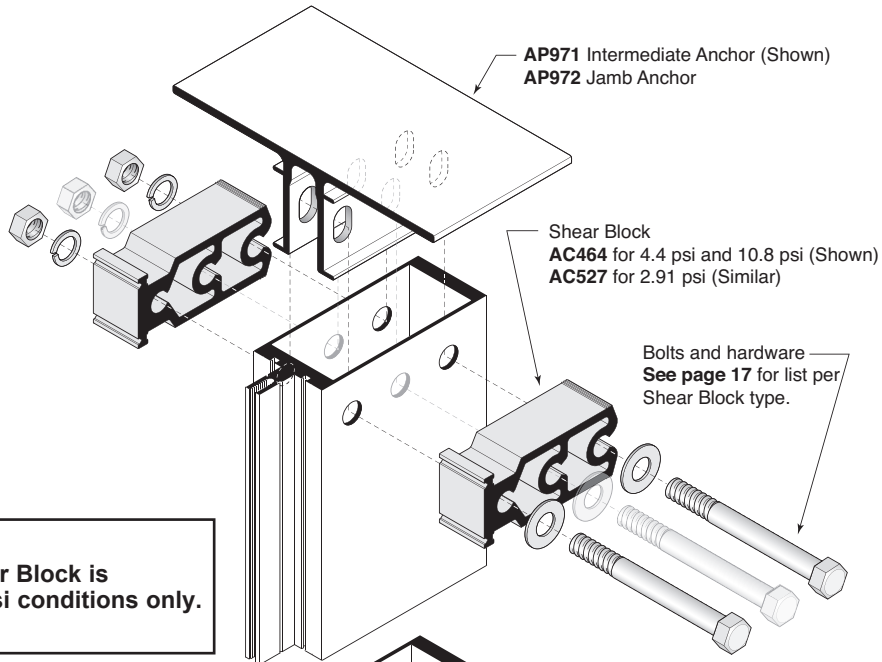

DETAIL N

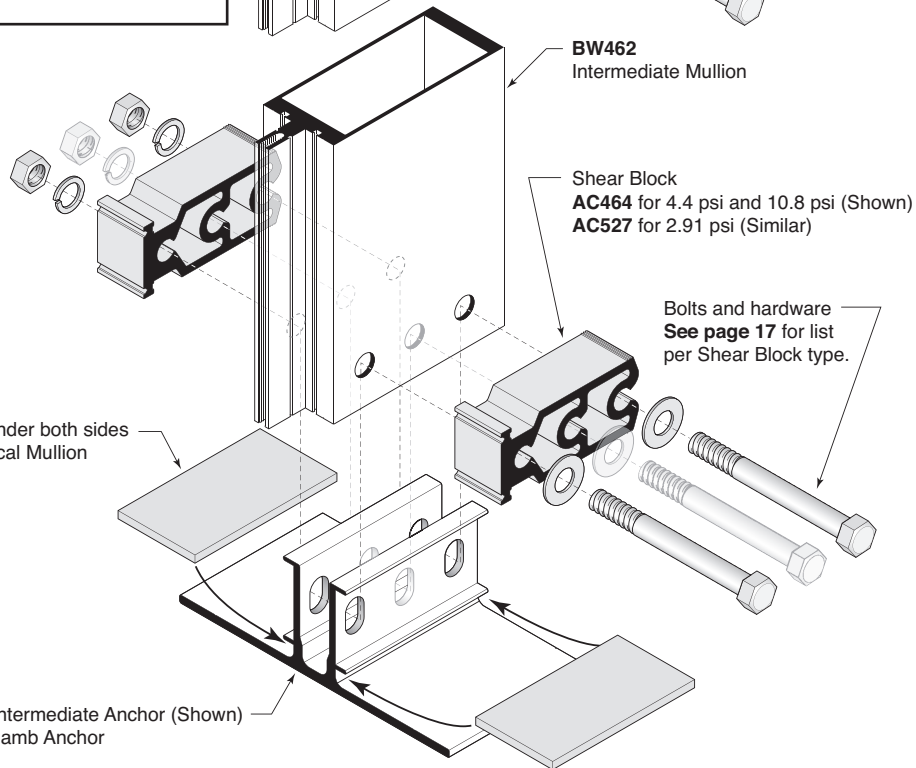

DETAIL O

# ASSEMBLY AND INSTALLATION

## SINGLE SPAN CORNER CONDITION

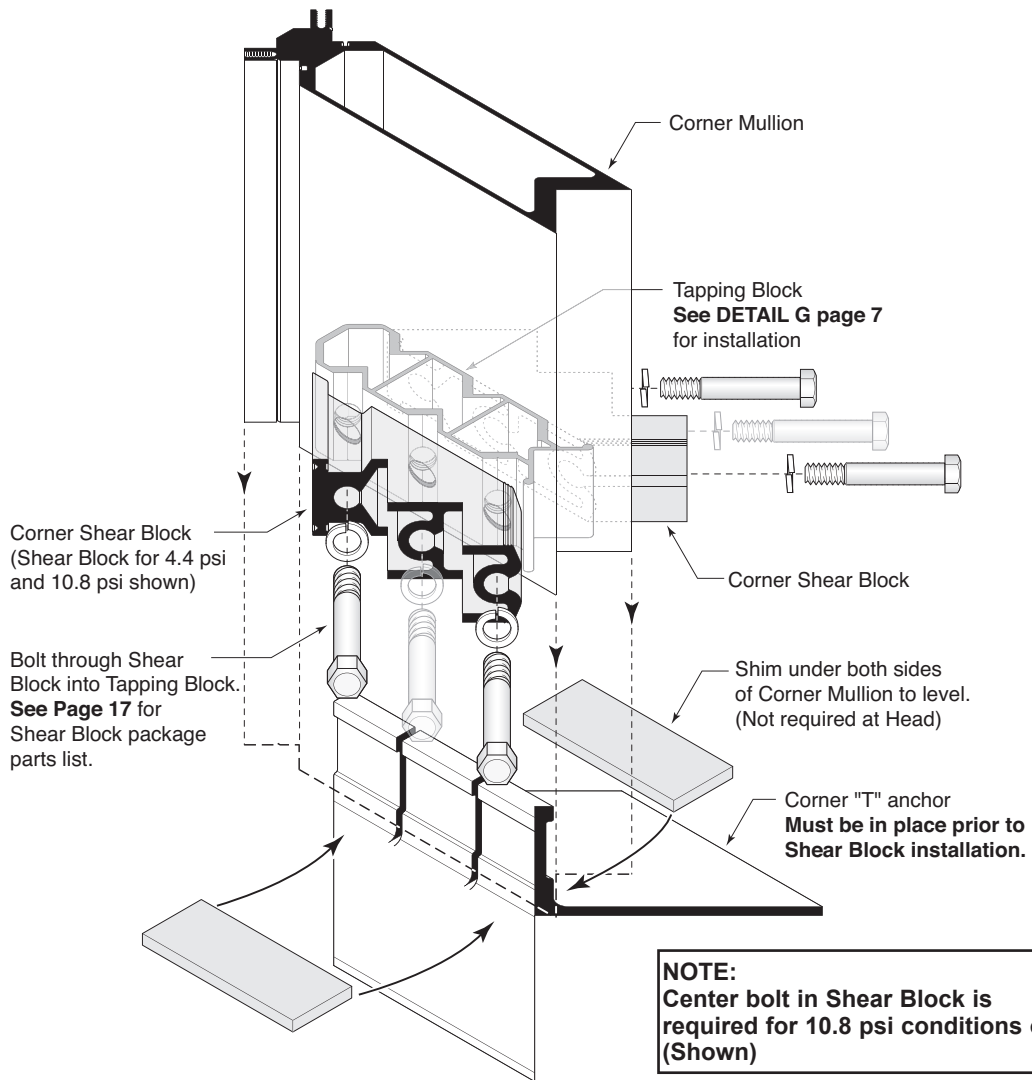

DETAIL P

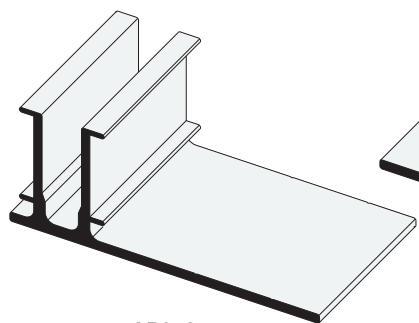

AP972  
JAMB ANCHOR

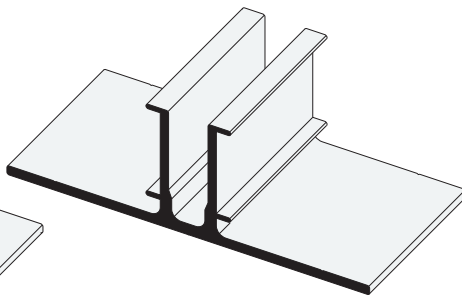

AP971  
INTERMEDIATE ANCHOR

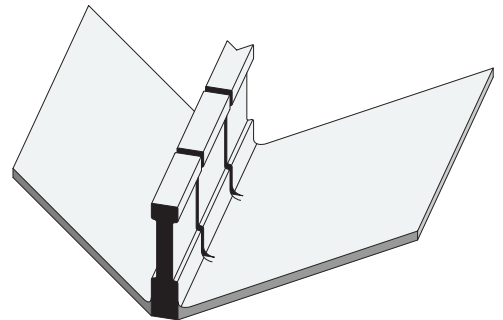

AP492  
CORNER ANCHOR

DETAIL Q

# ASSEMBLY AND INSTALLATION

## MULTI-SPAN INSTALLATION

1. Install lower jambs and mullions. Slide sill anchors into bottom of mullions. Stand mullions and plumb in place.
2. Attach sill anchor to substrate. Shim under both sides of mullion as required to adjust bottom to proper level. **See DETAIL O** on page 12 and **DETAIL P** on page 13. **NOTE:** Minimum caulk space is 5/8" (16).
3. Attach floor slab anchors to floor slab edge aligned as required for vertical, plumb, and true mullion erection.
4. Install upper jamb and mullions. Stand upper mullion above previously erected mullion. Remove tape holding splice sleeve in place allowing the sleeve to telescope into the lower mullion hitting the stop screw. **See DETAIL U** on page 15.
5. Secure splice sleeve to lower mullion with (4) #12 X 1" FH SMS (**Part 12X1FHPSMS**) provided. **See DETAIL V** on page 16.
6. Attach mullion to floor slab anchor. Using holes in steel anchor as template, match drill (4) .531" dia. holes (17/32" drill bit) on each side through mullion and reinforcement sleeve. Attach using bolts provided. Continue this procedure until all mullions of current level are installed. **See DETAILS R, S** on page 14 and **DETAIL T** on page 15.
7. Before erecting the extreme top mullion in a column, head anchor must be inserted into top of mullion. **See DETAIL N** on page 12. Secure head anchor to structure. Repeat steps 4 and 5 for splice sleeve engagement.

**NOTE:** Mullion spacing must be held to within +1/32" (0.8). Check overall frame dimension every four bays to monitor dimension build up.

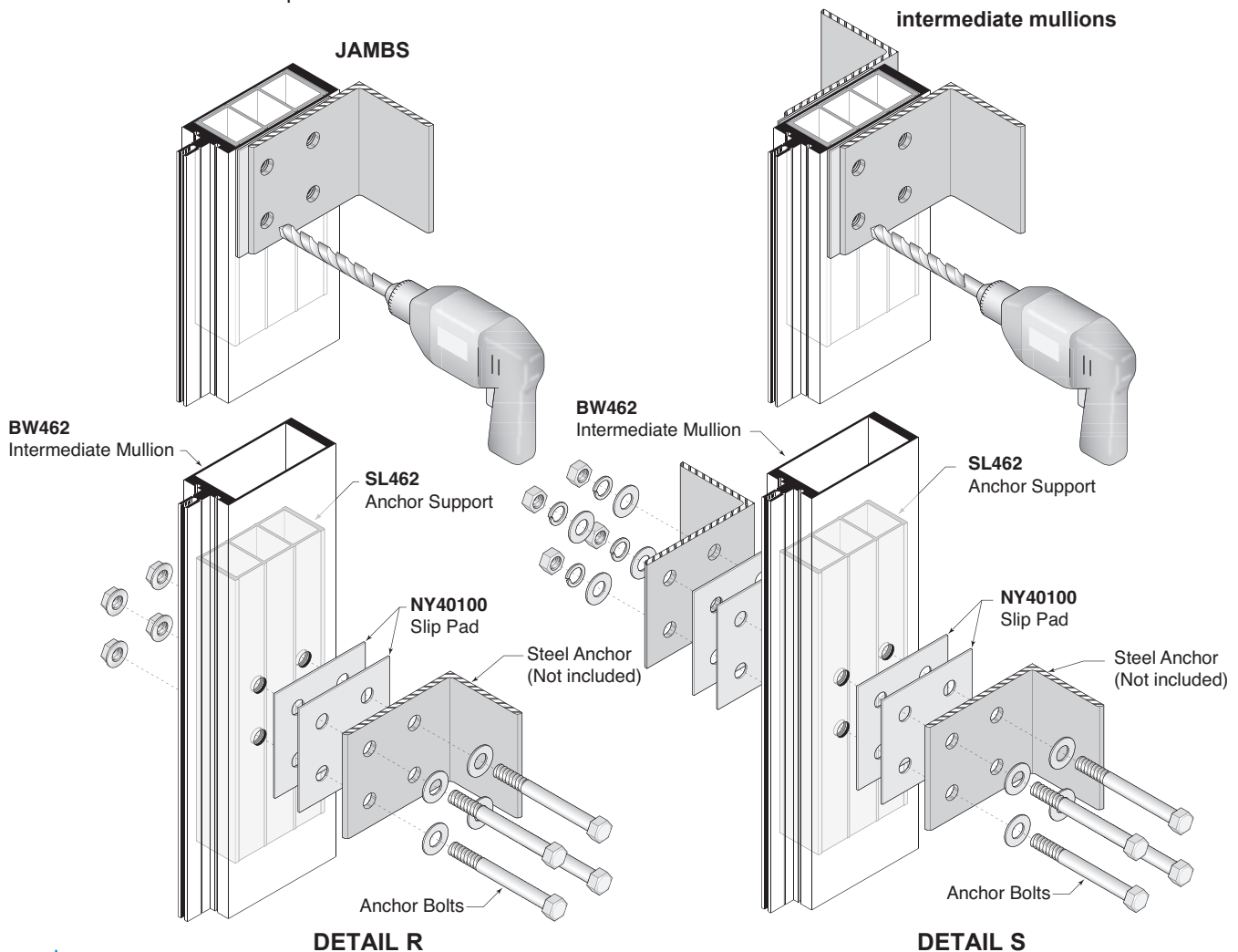

# ASSEMBLY AND INSTALLATION

## MULTI-SPAN CORNER INSTALLATION

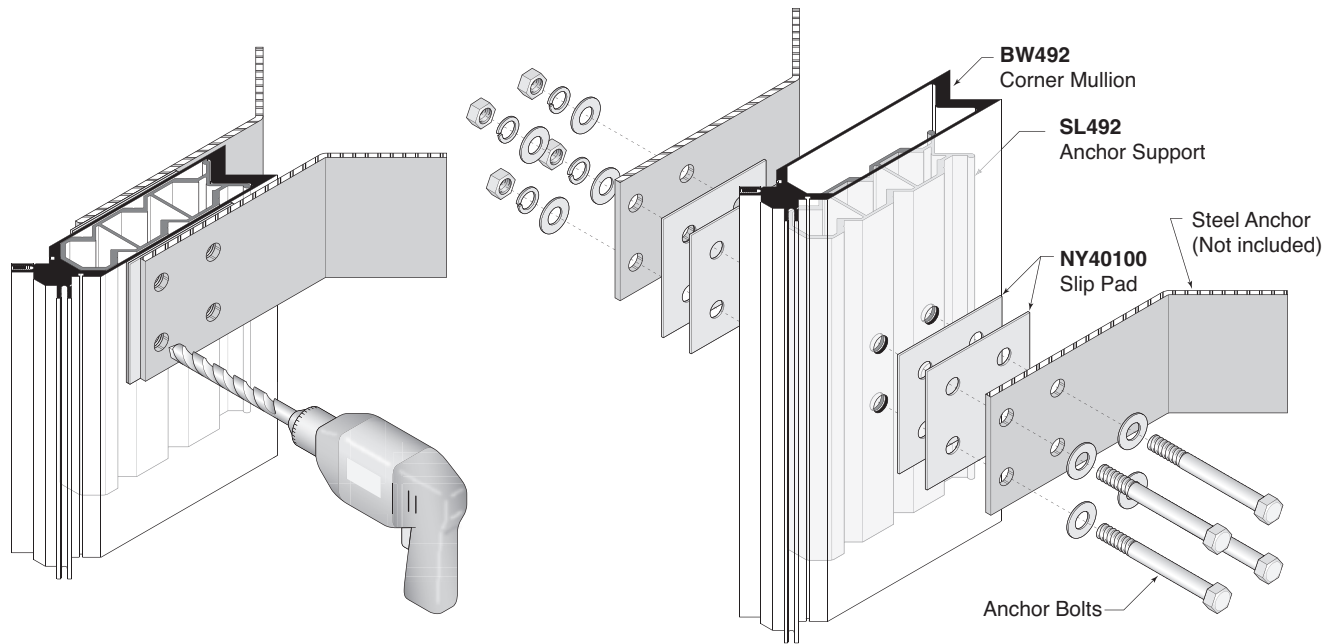

DETAIL T

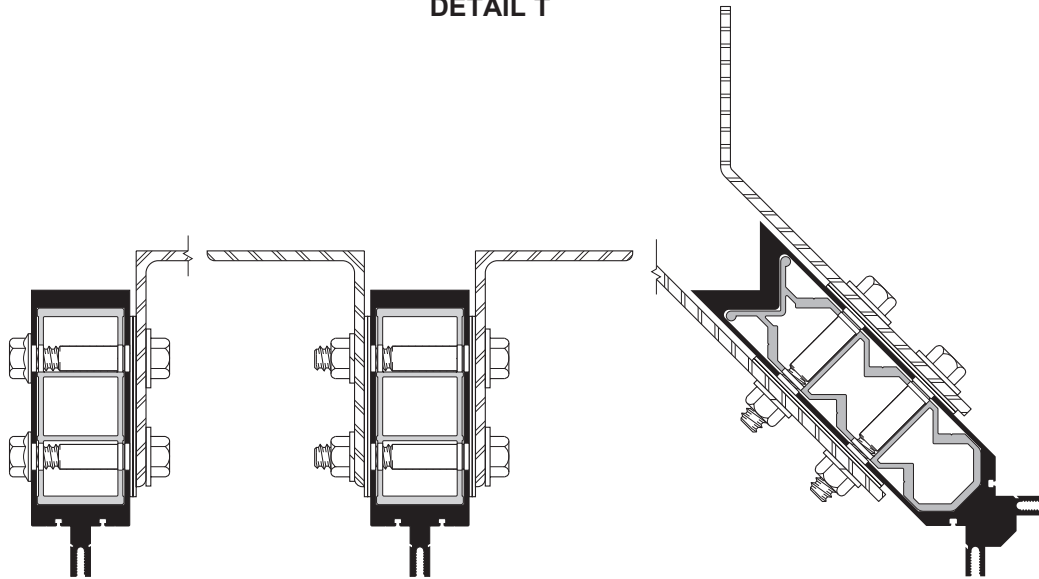

**AP481**

**Jamb Mullion Anchor:**

- (1) AP691 Anchor Support
- (2) NY40100 Slip Pads
- (4) 5/8" -11 x 3-1/2" GR5 Bolts
- (4) 5/8" Lock Washers

**AP482**

**Intermediate Mullion Anchor:**

- (1) AP691 Anchor Support
- (4) NY40100 Slip Pads
- (4) 5/8" -11 x 4-1/2" GR5 Bolts
- (4) 5/8" Flat Washers
- (4) 5/8" Lock Washers
- (4) 5/8" -11 Hex Nuts, NyLoc

**AP483**

**Corner Mullion Anchor:**

- (1) AP492 Anchor Support
- (4) NY40100 Slip Pads
- (4) 5/8" -11 x 4-1/2" GR5 Bolts
- (4) 5/8" Flat Washers
- (4) 5/8" Lock Washers
- (4) 5/8" -11 Hex Nuts, NyLoc

DETAIL U

# ASSEMBLY AND INSTALLATION

## SPLICING MULLION PRESSURE BAR AND FACE COVER

1. Install upper member and let splice sleeve slide down until it sits on top of stop screw. Match drill through lower mullion attachment holes into splice sleeve with #15 drill bit (.180"). Secure splice sleeve to lower mullion with (4) #12 X 1" FH SMS (Part 12X1FHPSMS) provided. See **DETAIL V**. Also see **Multi-Span Installation** on page 14.

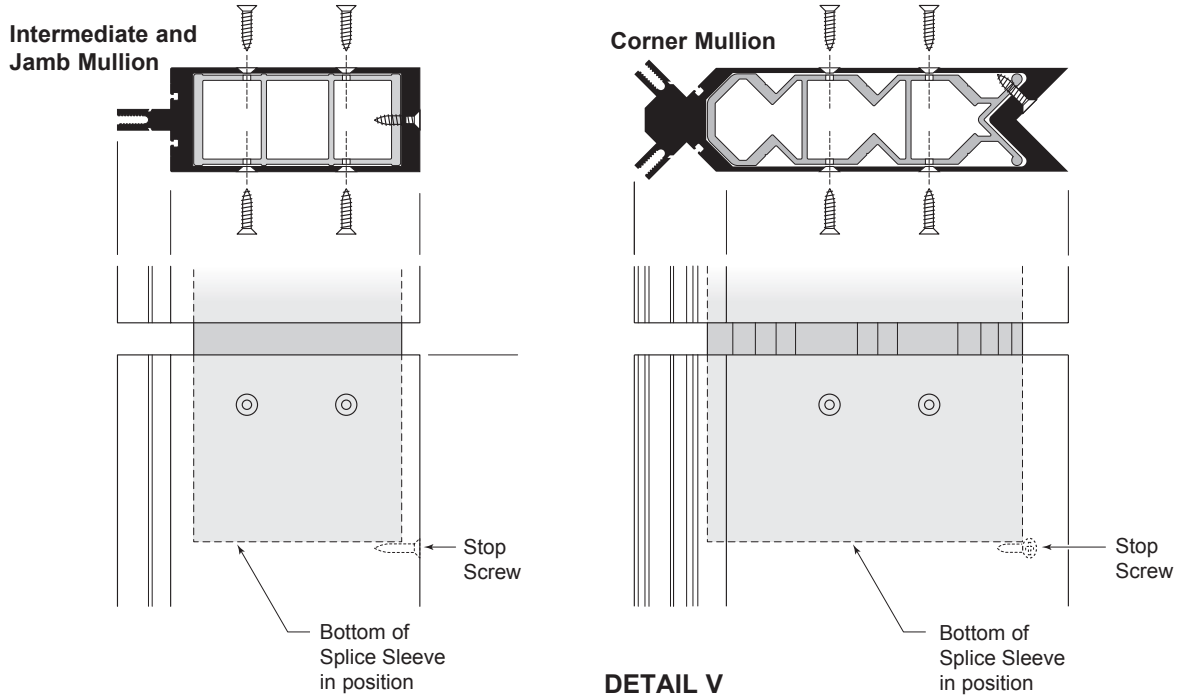

**DETAIL V**

2. Stagger joints on back members, pressure bars and face caps. Seal joints as shown on **DETAIL W**.
3. Seal pressure bar joint. See **DETAIL W**.

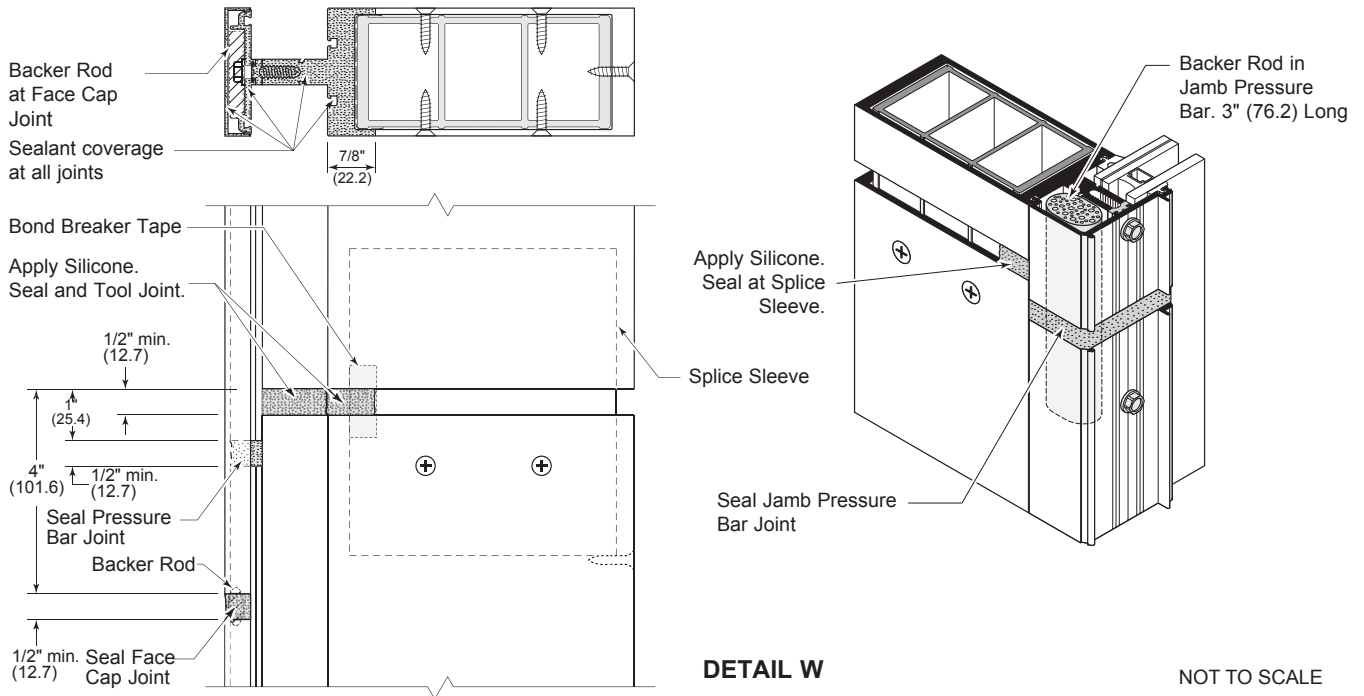

**DETAIL W**

NOT TO SCALE

[usalum.com](http://usalum.com)

V 2024-1007

Copyright © 2021 US Aluminum

All rights reserved.

™ ® Trademarks of US Aluminum and its affiliated companies or respective owners.



# ASSEMBLY AND INSTALLATION

## SHEAR BLOCK AND HORIZONTAL INSTALLATION

1. Attach shear blocks to vertical members. Install head, intermediate horizontal and sill shear blocks as shown in DETAILS X through Z.

**NOTE:** Intermediate shear blocks can be installed prior to mullion erection. Head and sill shear blocks must be installed after erection.

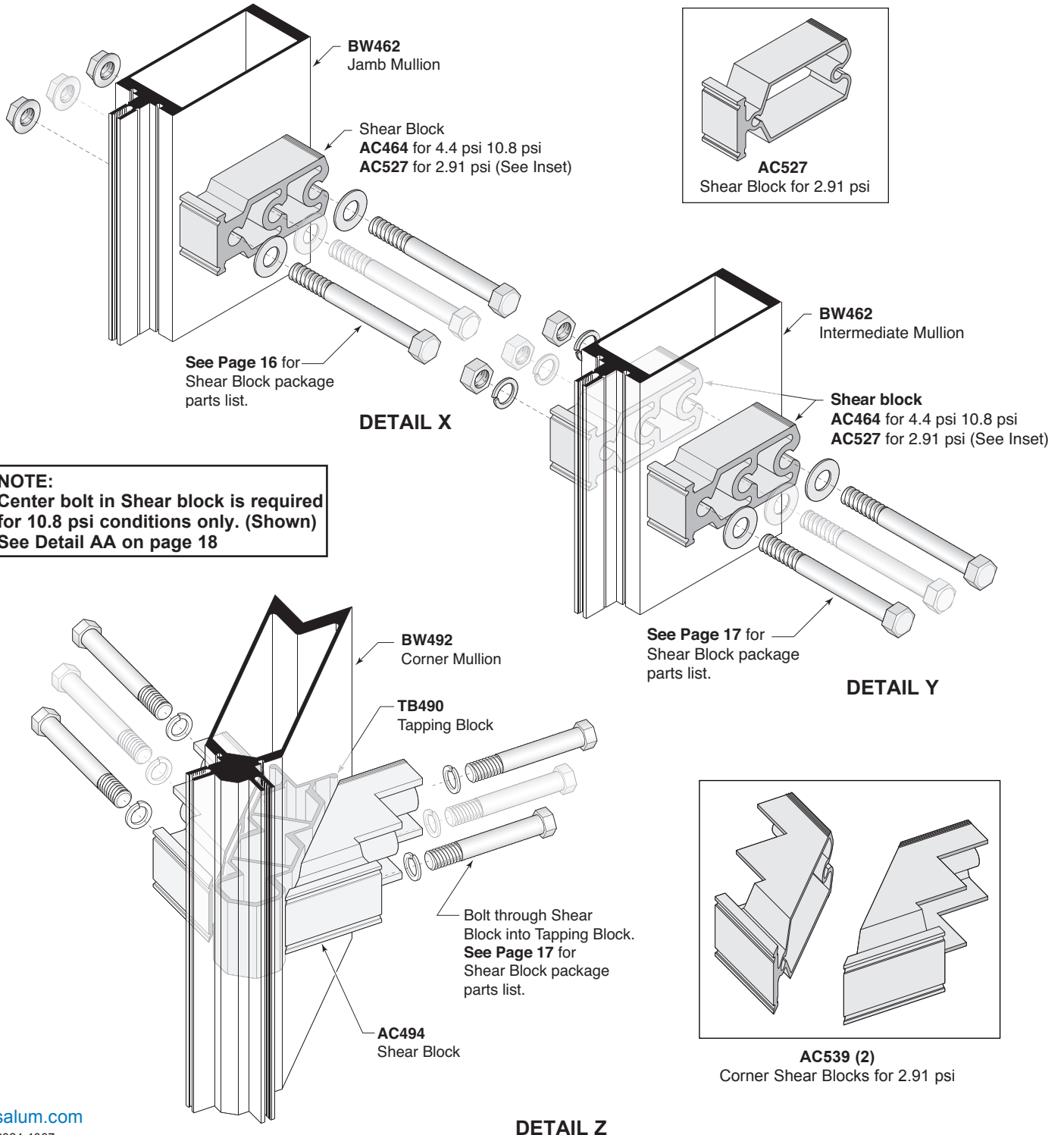

**NOTE:**  
Center bolt in Shear block is required for 10.8 psi conditions only. (Shown)  
See Detail AA on page 18

# ASSEMBLY AND INSTALLATION

## SHEAR BLOCK AND HORIZONTAL INSTALLATION (Continued)

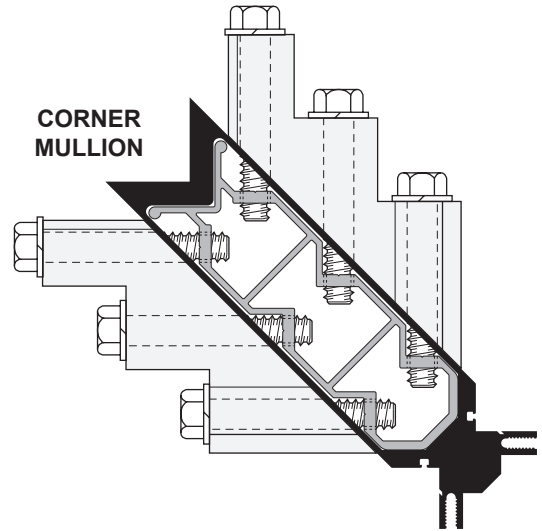
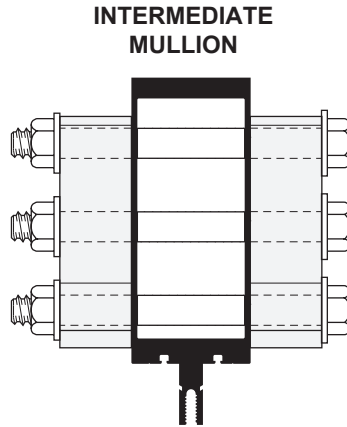
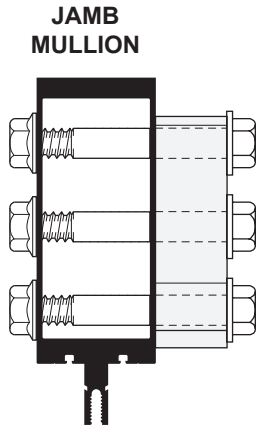

**AP53899 for 2.91 psi:**

- (1) **AC527** Shear block
- (2) **MF353** 3/8"-16 x 5" GR5 bolts
- (2) **MF251** 3/8" Flat Washers
- (2) **MF304** 3/8"-16 Flange Nut
- (2) **Part 12X1FHPSMS**

**APK464 for 4.4 psi:**

- (1) **AC464** Shear Block
- (2) **MF545** 5/8"-11 x 4-1/2" GR5 Bolts
- (2) **MF255** 5/8" Flat Washers
- (2) **MF529** 5/8"-11 Flange Nut
- (2) **Part 12X1FHPSMS**

**AP46799 for 10.8 psi (Shown):**

- (1) **AC464** Shear Block
- (3) **MF545** 5/8"-11 x 4-1/2" GR5 Bolts
- (3) **MF255** 5/8" Flat Washers
- (3) **MF529** 5/8"-11 Flange Nut
- (2) **Part 12X1FHPSMS**

**AP52799 for 2.91 psi:**

- (2) **AC527** Shear Blocks
- (2) **MF368** 3/8"-16 x 6-1/2" GR5 Bolts
- (2) **MF251** 3/8" Flat Washers
- (2) **MF265** 3/8"-16 Hex Nuts, NyLoc
- (4) **Part 12X1FHPSMS**

**AP46599 for 4.4 psi:**

- (2) **AC464** Shear Blocks
- (2) **MF565** 5/8"-11 x 6-1/2" GR5 Bolts
- (2) **MF255** 5/8" Flat Washers
- (2) **MF219** 5/8"-11 Hex Nuts, NyLoc
- (4) **Part 12X1FHPSMS**

**AP46899 for 10.8 psi (Shown):**

- (2) **AC464** Shear Blocks
- (3) **MF565** 5/8"-11 x 6-1/2" GR5 Bolts
- (3) **MF255** 5/8" Flat Washers
- (3) **MF219** 5/8"-11 Hex Nuts, NyLoc
- (4) **Part 12X1FHPSMS**

**AP53999 for 2.91 psi:**

- (2) **AC539** Shear Block
- (4) **MF342** 3/8"-16 x 4" GR5 Bolts
- (4) **MF254** 3/8" Lock Washers
- (1) **TB539** Tapping Block
- (5) **Part 12X1FHPSMS**

**APK494 for 4.4 psi:**

- (2) **AC494** Shear Block
- (4) **MF540** 5/8"-11 x 4" GR5 Bolts
- (4) **MF256** 5/8" Lock Washers
- (1) **TB490** Tapping Block
- (5) **Part 12X1FHPSMS**

**AP49799 for 10.8 psi (Shown):**

- (2) **AC494** Shear Block
- (6) **MF540** 5/8"-11 x 4" GR5 Bolts
- (6) **MF256** 5/8" Lock Washers
- (1) **TB490** Tapping Block
- (5) **Part 12X1FHPSMS**

### DETAIL AA

**NOTE:**  
Center bolt in Shear Block is required for 10.8 psi conditions only. (Shown)

# ASSEMBLY AND INSTALLATION

## SHEAR BLOCK AND HORIZONTAL INSTALLATION (Continued)

2. Apply sealant to shear block face prior to installing horizontal members as shown on **DETAIL BB**.
3. Roll horizontal members over shear blocks and secure with screws provided. See **DETAIL CC**.
4. Install snap-in horizontal fillers. See **DETAIL CC**.

**NOTE:** Snap-in fillers are optional at head and sill to facilitate interior caulking. Cut fillers 3-3/4" short to clear shear blocks. Snap fillers in place before installing head and sill members.

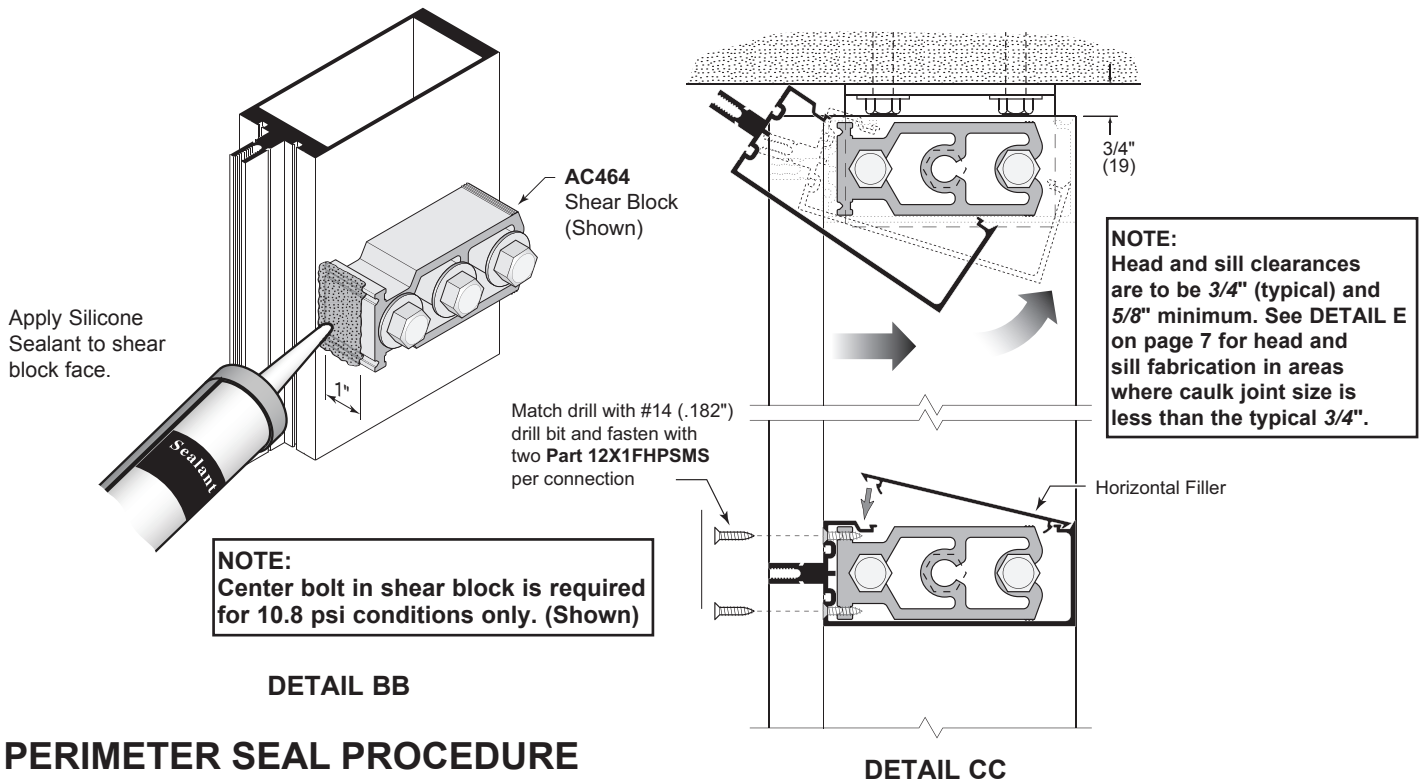

## PERIMETER SEAL PROCEDURE

1. Install closure plates at top and bottom of vertical mullions. See **DETAIL DD**.
2. Closure plates that occur at entrance locations must be trimmed flush with mullion edge at door side for door frame clearance. See **DETAIL DD**.

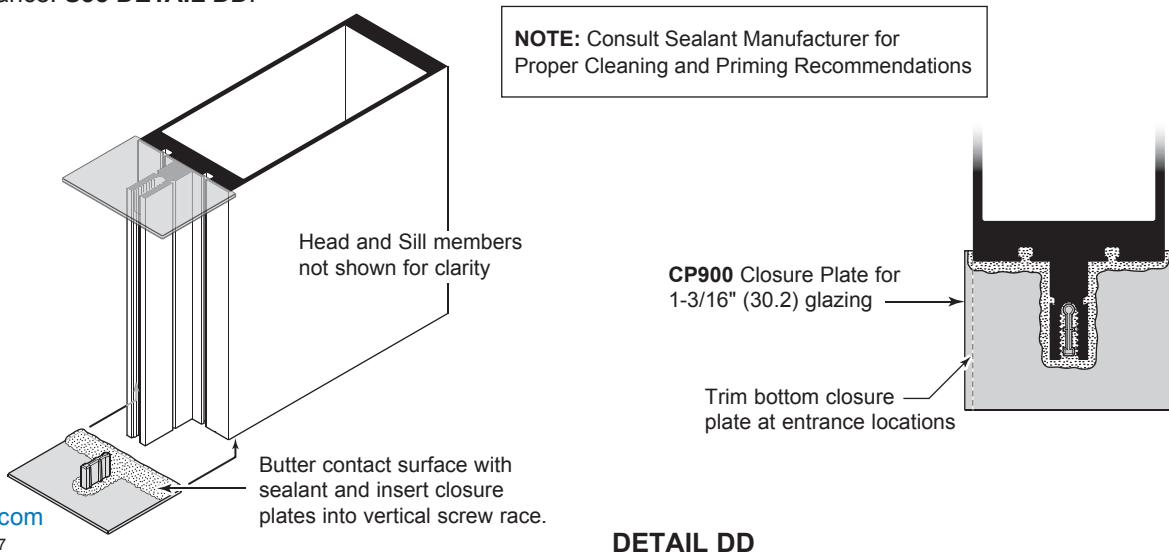

usalum.com

V 2024-1007

Copyright © 2021 US Aluminum

All rights reserved.

™ ® Trademarks of US Aluminum and its affiliated companies or respective owners.

# ASSEMBLY AND INSTALLATION

## PERIMETER SEAL PROCEDURE (Continued)

3. After back members are installed, seal around perimeter. Perimeter caulking must be completed prior to installation of glass and pressure bars. Ensure perimeter sealant has smooth transition across vertical closure plates. See **DETAIL EE**.

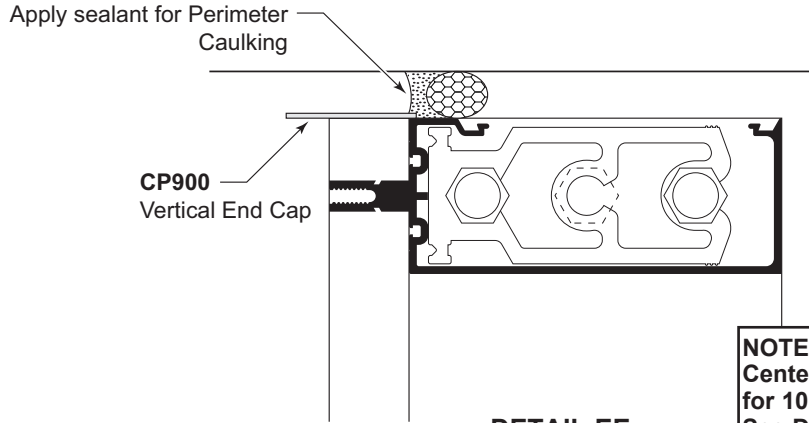

**DETAIL EE**

**NOTE:**  
Center bolt in Shear Block is required for 10.4 psi conditions only. (Dashed)  
See Detail AA on page 18

## GLAZING

### GLASS OPENING PREPARATION

1. Seal joint between horizontal and vertical. Seal over screw heads in the glazing pockets.
2. Apply silicone sealant at the three contact areas of End Dams and the vertical gasket reglet at the End Dam location. See **DETAIL FF**.
3. Slide End Dams into place. See **DETAIL FF**.  
**NOTE:** End Dams occur at head and sill also.

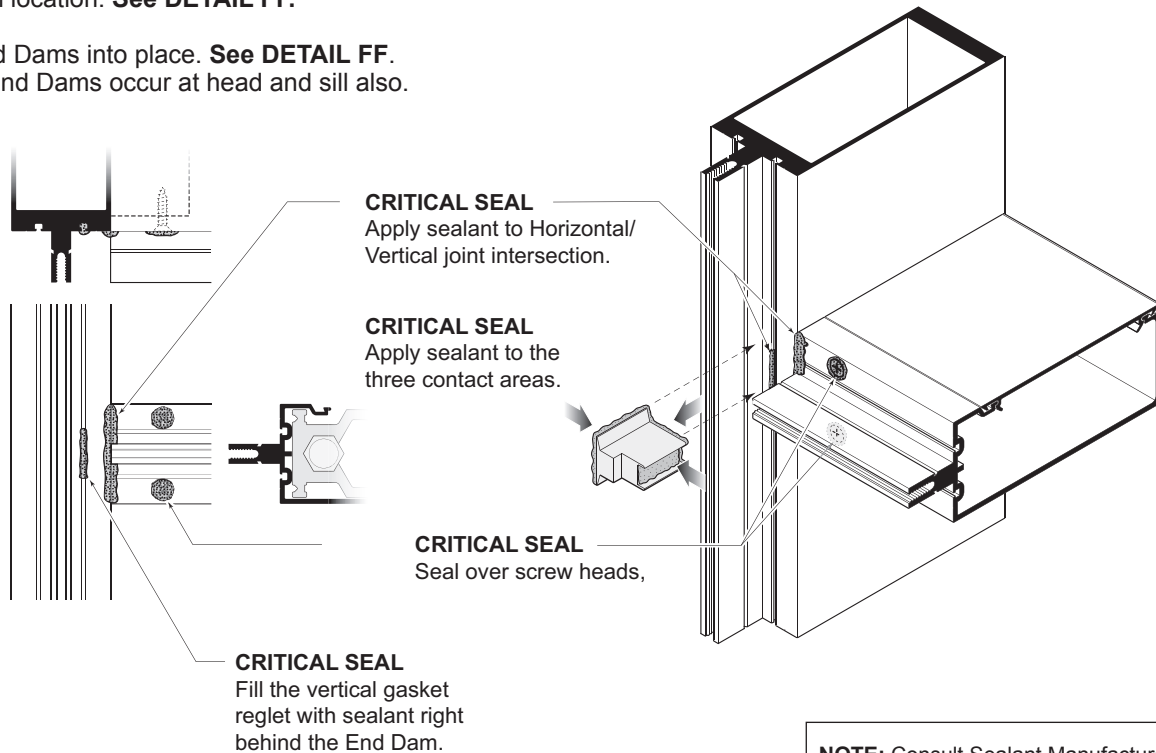

**DETAIL FF**

**NOTE:** Consult Sealant Manufacturer for Proper Cleaning and Priming Recommendations

# GLAZING

## GLASS OPENING PREPARATION (Continued)

4. Cut spacer gaskets to length. Vertical length is to be D.L.O. plus 1-5/8" (41.3). Horizontal length is to be D.L.O. plus 1-1/8" (28.2).
5. Cut dart from both ends of the horizontal spacer gaskets as shown in **DETAIL GG**.
6. Install interior spacer gaskets into vertical and horizontal members.
7. Install exterior gaskets into pressure bars. Horizontal pressure bar gaskets should extend 1/8" (3.2) beyond each end of the extrusions. Vertical pressure bar gaskets run continuous.
8. Apply silicone sealant to face of End Dams. This is a critical seal area.  
**See DETAIL HH.** This should be done immediately before installation of vertical pressure bar.

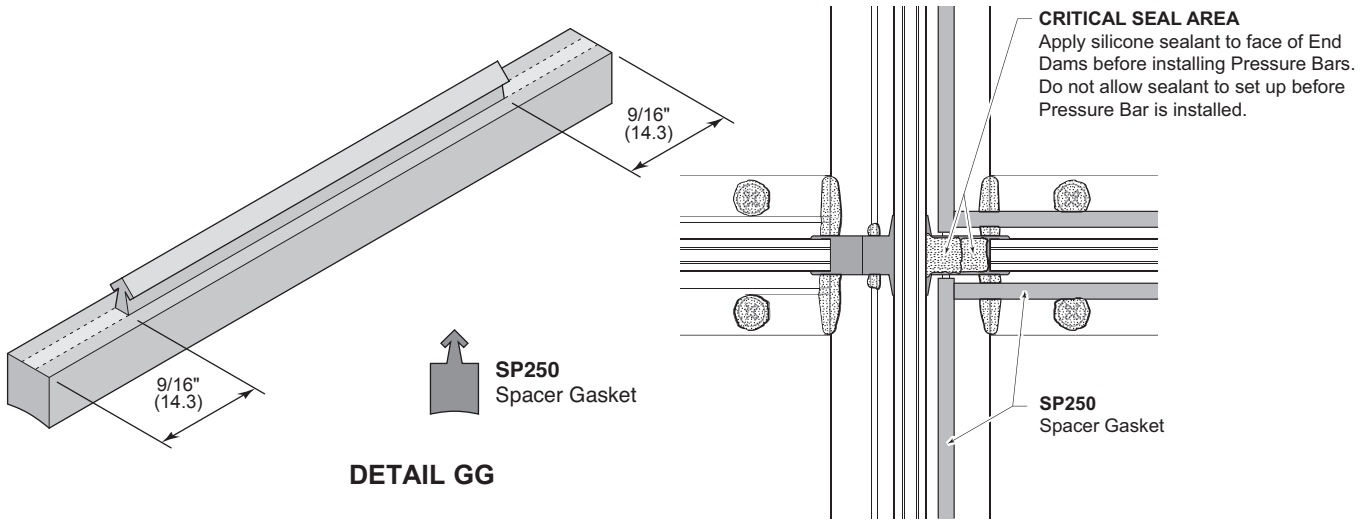

## GLASS INSTALLATION

**GLASS SIZES:** GLASS WIDTH AND HEIGHT = DAY LIGHT OPENING + 1-3/8" (34.9)

**NOTE:** Formula does not take into account glass tolerances. Consult glass manufacturer before ordering glass.

Remove exterior gaskets from carton and lay flat in a clean, dry area in order to recover shape. Allow gaskets to relax at least two hours at temperatures above 50°F (10°C). Glaze with gaskets above 40°F (4.44°C).

If necessary warm gaskets in a hot box before installing. Use **NP430** gasket at exterior. Cut gaskets allowing 1/8" (3.2) extra length per foot of extrusion to allow for shrinkage.

1. Install setting blocks. Position two setting blocks for each lite of glass at quarter points or per approved shop drawings. **See DETAIL II.**

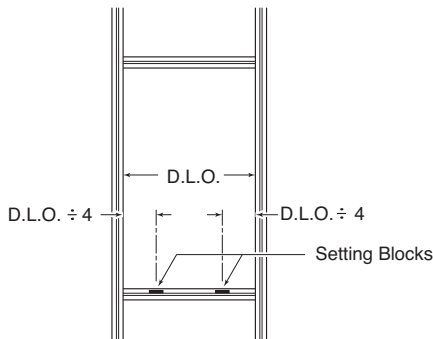

NOT TO SCALE

# GLAZING

## GLASS INSTALLATION (Continued)

2. Install glass and center in opening. Use **CW368** temporary glass retainers to hold glass in place until pressure bars are installed. Install temporary glass retainer at corners and one at mid-light. **See DETAIL JJ.**

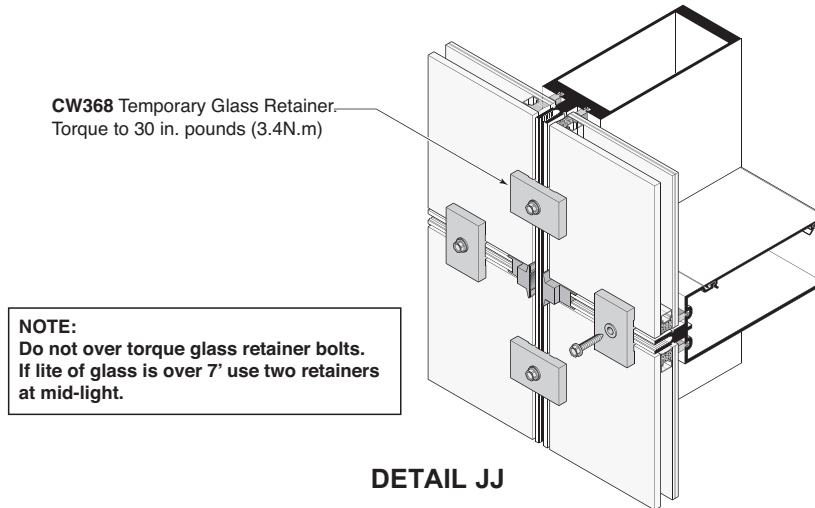

## PRESSURE BAR INSTALLATION

Install vertical pressure bar bolts from bottom to top and horizontal pressure bar bolts from center outward. Always locate bolts 1-1/2" (38.1) maximum from vertical/horizontal intersections to ensure proper pressure over end dams. **See DETAIL BB. Be sure pressure bar spacer is not disengaged.**

**NOTE: See DETAIL V** on page 16 for pressure bar splice condition.

1. Install gaskets into vertical and horizontal pressure bars.
2. Install vertical pressure bars first. Leave 1/8" (3.2) gaps at top and bottom. Using a speed wrench, torque bolts to 30 inch pounds (3.4 N.m). Increase torque to 50-60 inch pounds, (5.7 to 6.8 N.m) minimum after all four sides have been secured.
3. Center horizontal pressure bars in opening, leaving 1/8" (3.2) gaps at each end.  
**NOTE:** weep slots **must be** in top side of all horizontal pressure bars and level with bottom of glazing pocket to ensure proper drainage. **See DETAIL KK.**
4. Seal gaps at vertical/horizontal intersections, screw heads, and at top and bottom of vertical pressure bars. **See DETAIL KK.**

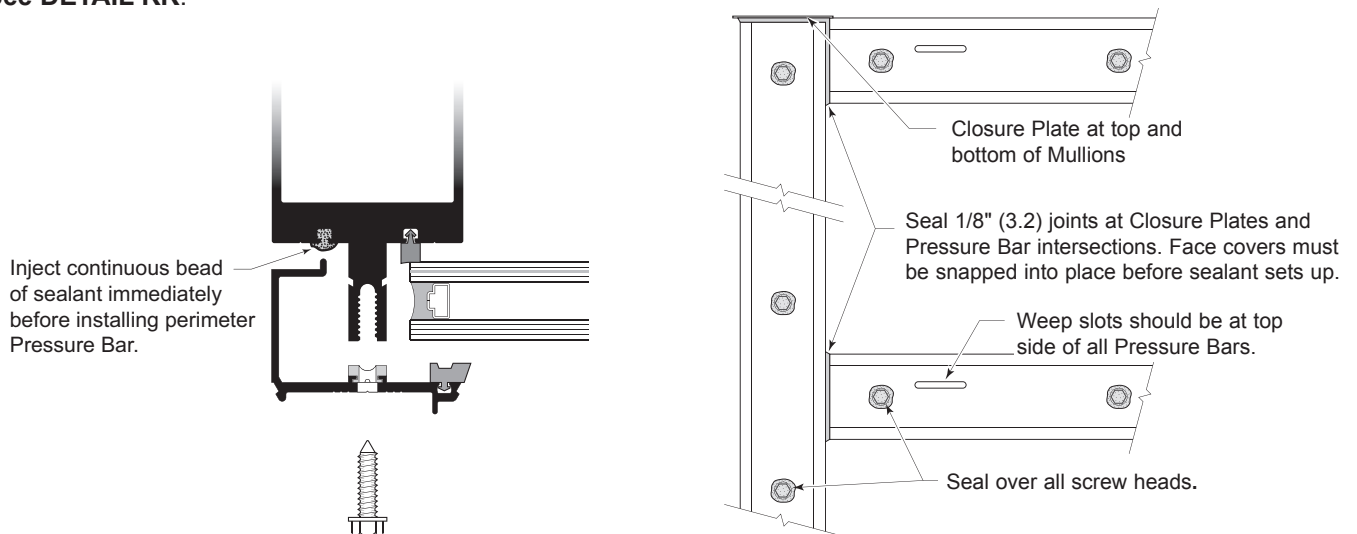

# GLAZING

## STRUCTURAL SILICONE

Aluminum framing surfaces and glass edge areas to receive structural silicone must be clean.

1. Inject structural silicone into space between glass and back members on all four sides of opening and tool. See **DETAIL LL**. Follow manufacturer's recommendations for cure times.  
**NOTE: Always follow structural silicone manufacturer's instructions and recommendations for surface preparation and silicone application.**

**NOTE: Silicone must be free of air pockets or bubbles and penetrate full depth of space continuously.**

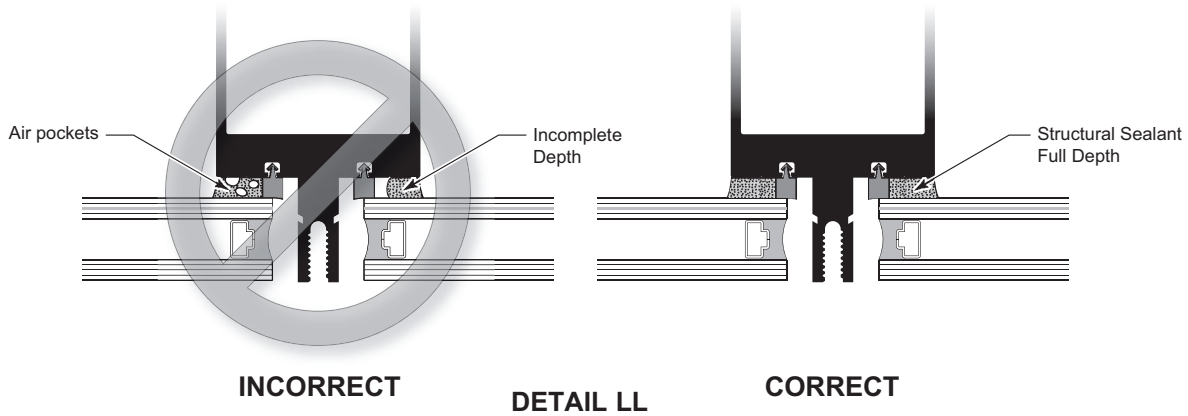

## FACE COVER INSTALLATION

Care must be taken to prevent damage of face covers during installation. Use a piece of wood such as 2" x 4" x 12" (50 x 100 x 300) and a Dead Blow Hammer. See **DETAIL MM**.

1. Install vertical face covers first. Do not disturb top and bottom closure plates when installing face covers. Pinning of vertical face cover is required to prevent slippage. Use one pin on each side per cut length concealed behind horizontal face cover. See **DETAIL NN**.
2. Install horizontal face covers with the weep holes located on the bottom side.

**NOTE: See DETAIL P on page 13 for face cover splice condition.**

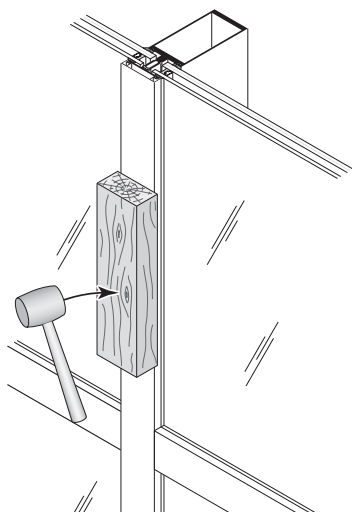

**DETAIL MM**

1/16" x 1/2" (1.6 x 12.7) roll pin at center of cut length on each side. (Concealed behind Horizontal Face Cover)

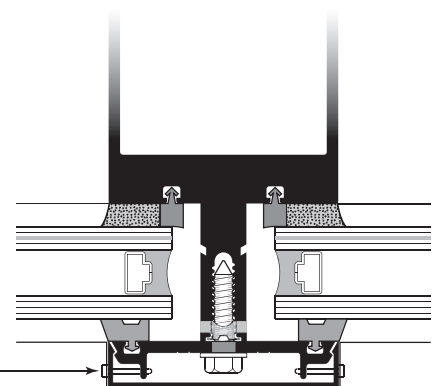

**DETAIL NN**